

PC3-SERIES

PC3-XY12 / PC3-XY24 Datasheet

Description

- PC3 Series detectors can reliably detect flammable, toxic gases and oxygen in industrial environments.
- PC3 Series are Category 3 devices and can be used in Zone 2 applications.
- PC3 Series has two sensor head options which are SH10 and SH20. SH10 is improved for hydrocarbon gases and SH20 is improved for toxic gases.

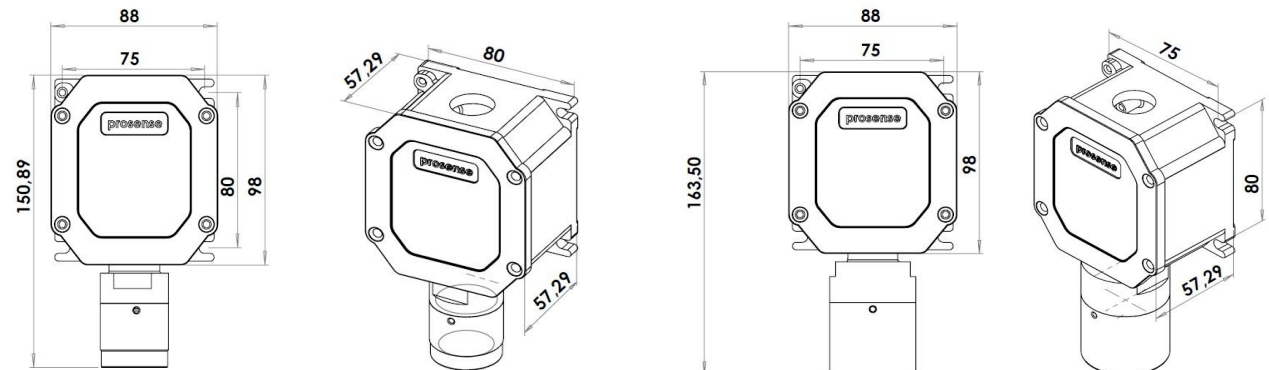

With SH10

With SH20

- 4-20mA Analog Output
- Die Cast Aluminium Junction Box
- Atex Certified Sensor Head and Cable Gland
- IP65 Protection Class
- Optional (P-3R) Relay Card
- Optional RS485 (Modbus RTU) Interface module

Table 1: PC3 Flammable Gas detectors

XY	Gases	Product Code	Measuring Range	LEL(Vol)
30	LPG	PC3-3012	0-100% LEL	1,8
31	Methane	PC3-3112	0-100% LEL	4,4
32	Petrol Vapors	PC3-3212	0-100% LEL	1,2
33	n-Butane	PC3-3312	0-100% LEL	1,6
34	Propane	PC3-3412	0-100% LEL	2,1
36	Hydrogen	PC3-3612	0-100% LEL	4

Table 2: PC3 Toxic Gas detectors

XY	Gases	Product Code	Measuring Range	TLV-TWA
44	Carbon Monoxide	PC3-4424	0-300 ppm	50 ppm
44	Carbon Monoxide	PC3-4424/B	0-500 ppm	50 ppm
44	Carbon Monoxide	PC3-4424/C	0-1000 ppm	50 ppm
48	Ammonia	PC3-4824	0-100 ppm	50 ppm
48	Ammonia	PC3-4824/B	0-1000 ppm	50 ppm
62	Ethylene Oxide	PC3-6224	0-20 ppm	1 ppm
64	Hydrogen Sulfur	PC3-6424	0-100 ppm	20 ppm
65	Oxygen*	PC3-6524	0-25% Vol	19,50% Vol
66	Sulfur Dioxide	PC3-6624	0-10 ppm	5 ppm
67	Nitric Oxide	PC3-6724	0-250 ppm	25 ppm
68	Nitrogen Dioxide	PC3-6824	0-30 ppm	5 ppm
69	Chlorine	PC3-6924	0-10 ppm	1 ppm
72	Freon**	PC3-7221	0-2000 ppm	-

*Oxygen is not toxic gases. It is listed in this table because it is using electrochemical sensor.

** For Freon, there is a special case, therefore, they use different type sensing element and sensor head.

Applications

- Boiler rooms
- Laboratories
- Light industrial environments

Specification	Flammable Gases	Toxic Gases
Sensing Element	Catalytic	Electrochemical
Measurement Unit	LEL	ppm
Output Signal	4-20mA	4-20mA
Connection	3-Wire	3-Wire
Sensor Warm-up Time	60 sec	60 sec
Response Time(T90)	<25 sec	<45 sec
Measuring Range	0-100% LEL	see the Table 2
Accuracy	%±2	%±2
Operating Temperature	-20°C ~ +50°C	-20°C ~ +50°C
Humidity	5 ~ 95 %RH	5 ~ 95 %RH
Input	12-24 VDC	12-24 VDC
Power Consumption	Max. 5W	Max. 5W
Output Options	Optional 3 NO/NC Relay Optional Modbus RS485	Optional 3 NO/NC Relay Optional Modbus RS485
Optional Relay Outputs	2 Alarm, 1 Fault NO/NC De-energized	2 Alarm, 1 Fault NO/NC De-energized
Cable Entry	1/2" NPT Cable Gland	1/2" NPT Cable Gland
IP Rating	IP65	IP65
Junction Box	Die-cast aluminium	Die-cast aluminium
Sensor Head	Nickel-plated Brass SH10 Ex II 2GD Ex d IIC Gb	Nickel-plated Brass SH20 Ex II 2GD Ex d IIC Gb
Dimensions/Weight	88x150,89x57,29mm (850gr)	88x163,5x57,29mm (1090gr)
Hazardous Class	Zone 2, Category 3	Zone 2, Category 3
Standards	EN 60079-0 EN 60079-1 EN 60079-18	EN 60079-0 EN 60079-1 EN 60079-18

Optional Modules

- PC3-3R: 2 Alarm, 1 Fault, 1x4-20mA relay card
- PC3-RS: 1 Modbus RTU, 1x4-20mA output RS485 relay card
- PC3-IP66: IP66 Sensor head(only for SH20)

- ProSense gas detectors are fully tested and calibrated before delivery. Gas Detectors must be routinely checked and calibrated to ensure fully operational at all times regarding EN 60079:29-2.

PC3-SERIES

PC3-7221 Datasheet

Description

- PC3 Series detectors can reliably detect flammable/explosive gases, toxic gases and oxygen in industrial environments.
- PC3 Series are Category 3 device and can be used in Zone 2 applications.
- PC3 Series has two sensor head options which are SH10 and SH20. SH10 is improved for hydrocarbon gases and SH20 is improved for toxic gases.

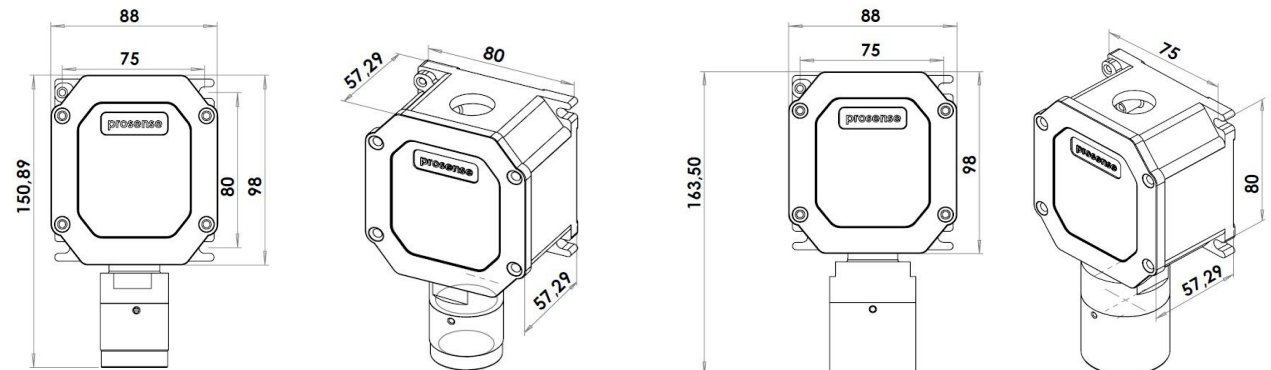

With SH10

With SH20

- 4-20mA Analog Output
- Die Cast Aluminium Junction Box
- Atex Certified Sensor Head and Cable Gland
- IP65 Protection Class
- Optional (P-3R) Relay Card
- Optional RS485 (Modbus RTU) Interface module

Table 1: PC3 Flammable Gas detectors

XY	Gases	Product Code	Measuring Range	LEL(Vol)
30	LPG	PC3-3012	0-100% LEL	1,8
31	Methane	PC3-3112	0-100% LEL	5
32	Petrol Vapors	PC3-3212	0-100% LEL	1,2
33	n-Butane	PC3-3312	0-100% LEL	1,6
34	Propane	PC3-3412	0-100% LEL	2,1
36	Hydrogen	PC3-3612	0-100% LEL	4

Table 2: PC3 Toxic Gas detectors

XY	Gases	Product Code	Measuring Range	TLV-TWA
44	Carbon Monoxide	PC3-4424	0-300 ppm	50 ppm
44	Carbon Monoxide	PC3-4424/B	0-500 ppm	50 ppm
44	Carbon Monoxide	PC3-4424/C	0-1000 ppm	50 ppm
48	Ammonia	PC3-4824	0-100 ppm	50 ppm
48	Ammonia	PC3-4824/B	0-1000 ppm	50 ppm
62	Ethylene Oxide	PC3-6224	0-20 ppm	1 ppm
64	Hydrogen Sulfur	PC3-6424	0-100 ppm	20 ppm
65	Oxygen*	PC3-6524	0-25% Vol	19,50% Vol
66	Sulfur Dioxide	PC3-6624	0-10 ppm	5 ppm
67	Nitric Oxide	PC3-6724	0-250 ppm	25 ppm
68	Nitrogen Dioxide	PC3-6824	0-30 ppm	5 ppm
69	Chlorine	PC3-6924	0-10 ppm	1 ppm
72	Freon	PC3-7221	0-2000 ppm	-

*Oxygen is not toxic gases. It is listed in this table because it is using an electrochemical sensor.

Applications

- Boiler rooms
- Laboratories
- Light industrial environments

Specification	PC3-7221
Sensing Element	Semiconductor
Measurement Unit	ppm
Output Signal	4-20mA
Connection	3-Wire
Sensor Warm-up Time	60 sec
Response Time(T90)	<5 sec
Measuring Range	0-2000 ppm
Accuracy	%±5
Operating Temperature	-20°C ~ +50°C
Humidity	5 ~ 95 %RH
Input	12-24 VDC
Power Consumption	Max. 5W
Output Options	Optional 3 NO/NC Relay Optional Modbus RS485
Optional Relay Outputs	2 Alarm, 1 Fault NO/NC De-energized
Cable Entry	1/2" NPT Cable Gland
IP Rating	IP65
Junction Box	Die-cast aluminium
Sensor Head	Nickel-plated Brass SH20 Ex II 2GD Ex d IIC Gb
Dimensions/Weight	88x163,5x57,29mm (1090gr)
Hazardous Class	Zone 2, Category 3
Standards	EN 60079-0 EN 60079-1 EN 60079-18

Optional Modules

- PC3-3R: 2 Alarm, 1 Fault, 1x4-20mA relay card
- PC3-RS: 1 Modbus RTU, 1x4-20mA output RS485 relay card
- PC3-IP66: IP66 Sensor head(only for SH20)
- ProSense gas detectors are fully tested and calibrated before delivery. Gas Detectors must be routinely checked and calibrated to ensure fully operational at all times regarding EN 60079:29-2.