

# PPS Series

## PPS Series Datasheet



### Description

- Prosense PPS-CO and PPS-NO2 addressable gas detectors for continuously monitor carbon monoxide and nitrogen dioxide gases in closed area car parks.
- PPS series gas detectors communicate to PPS Manager Control Panel via RS485 serial connection.

### PPS Manager Descriptions

- Up to 4 open loops.
- Up to 32 detectors for each loop (total 128 detectors)
- Monitoring average or high alarm levels.
- Monitoring each detector separately
- 2x8 LCD screen for each zone.
- 5 individual LED status for each zone.
- 2 Alarm relays for each zone.
- 1 Alarm and 1 Fault relay output to monitor overall system status.
- Up to 1 km cable length.
- 2x12V-4.3A battery connections.

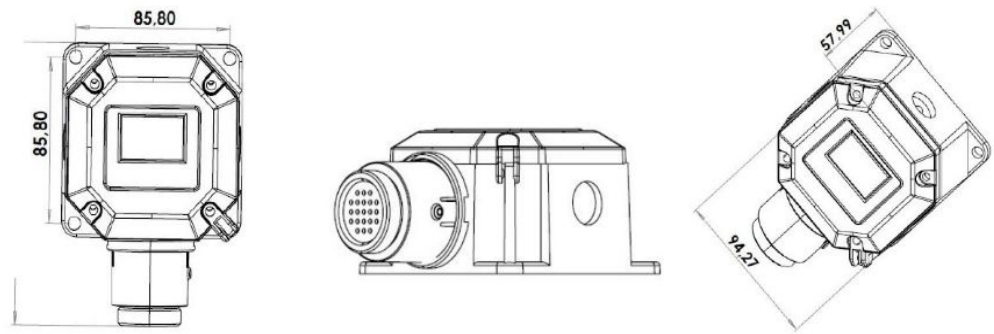
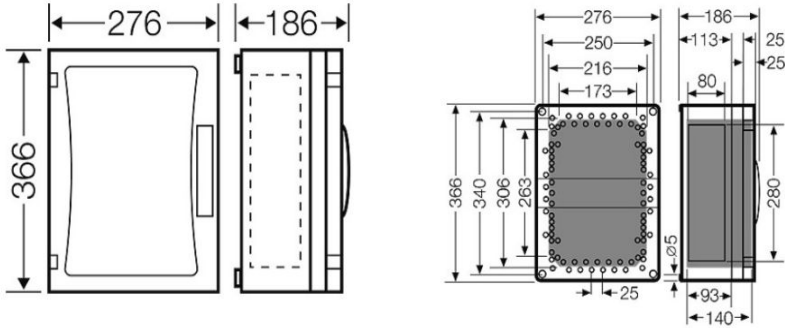

Detector Specification	PPS-CO	PPS-NO2
Target Gas	Carbon Monoxide	Nitrogen Dioxide
Sensing Element	Electrochemical	Electrochemical
Measurement Type	ppm	ppm
Output Signal	RS485 Modbus RTU	RS485 Modbus RTU
Connection	4-Wire (RS 485)	4-Wire (RS 485)
Sensor Warm-up Time	60 sec	60 sec
Response Time (T90)	<30 sec	<30 sec
Measuring Range	0-300 ppm	0-30 ppm
Accuracy	%±2	%±2
Operating Temperature	-20°C ~ +50°C	-20°C ~ +50°C
Humidity	5 ~ 95 %RH	5 ~ 95 %RH
Input	12-24 VDC	24 VDC
Power Consumption	Max. 2W	Max. 2W
Cable Entry	PG 11	PG 11
IP Rating	IP54	IP54
Junction Box	ABS Plastic	ABS Plastic
Sensor Head	SH40 ABS Cabinet	SH40 ABS Cabinet
Dimensions/Weight	103x63x170mm (230gr)	103x63x170mm (230gr)
Hazardous Class	Out Of Zone	Out Of Zone
Standards	CE(pending) EN 50270 EN 61000-6-3 EN 60000-3-3 EN 60000-3-2	CE(pending) EN 50270 EN 61000-6-3 EN 60000-3-3 EN 60000-3-2

Panel Specification	PPS Manager
Power Source	220VAC +/- 10%
Power Consumption	27VDC/200mA-5.4Wmax. without connected detectors
Inputs (Internal)	4x32 detectors via RS485 serial input
Relay Outputs	Fan1, Fan2, Fault for each zone Fault and Alarm for overall status
Contacts Rating	3A, 24VDC or 3A 120VAC
Display	Graphic LCD (2x8)
LED indicators	Fan1, Fan2, Alarm Power/ON, Fault, Alarm LEDs
Backup Battery	2x12V 7A/h (Optional)
Operating Temp.	0-50°C
Humidity	15-85%non condensing
Housing	ABS IP65
Dimession/Weight	366x276x186mm 5.5 kg
Main Power Fuse	2A
Backup Battery Fuse	2A

- Prosense gas detectors are fully tested and calibrated before delivery.